

# Emulation

Dr.-Ing. Volkmar Sieh

Department Informatik 4  
Verteilte Systeme und Betriebssysteme  
Friedrich-Alexander-Universität Erlangen-Nürnberg

WS 2017/2018



Wikipedia:

*Als Emulation wird in der Computertechnik das funktionelle Nachbilden eines Systems durch ein anderes bezeichnet. Das nachbildende System erhält die gleichen Daten, führt die gleichen Programme aus und erzielt die gleichen Ergebnisse wie das originale System.*



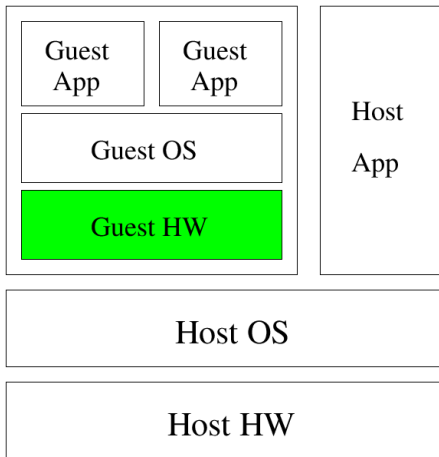

Beispiel:

System mit einem Bus mit angeschlossener CPU, RAM, ROM, einem seriellen Terminal und einer Platte.

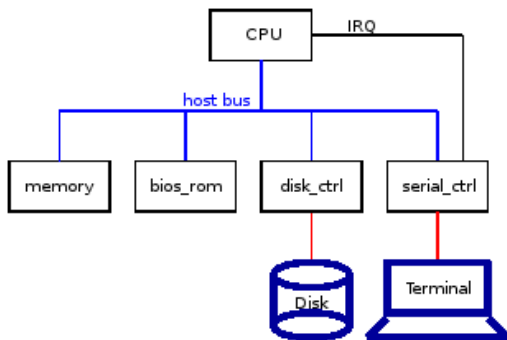

Idee System-Simulationsschleife:

```
while (1) {  
    /* bus_step(); */  
    cpu_step();  
    /* ram_step(); */  
    /* rom_step(); */  
    ser_step();  
    disk_step();  
}
```



```
void
cpu_step()
{
    if (! power) {
        /* Do nothing... */
    } else if (ieflag && interrupt_pending) {
        cpu_exec_interrupt();
    } else {
        cpu_exec_instruction();
    }
}
```

In der Praxis häufig sehr aufwändig:

- verschiedene Interrupt-Typen,
- verschiedene Exceptions, Halt-Zustände,
- ...



```
void cpu_exec_instruction() {
    inst = load(ip++); /* Get Instruction */
    switch (inst) {
    case ADD: /* add imm, %accu */
        imm = load(ip++); /* Get Op */
        accu += imm;
        break;
    case OUT: /* out %accu, port */
        port = load(ip++); /* Get Port */
        out(port, accu);
        break;
    case JMP: /* jmp addr */
        ip = load(ip); /* Get Address */
        break;
    ...
    }
}
```



```
void
cpu_exec_interrupt()
{
    interrupt_pending = 0;

    store(--sp, ip);
    store(--sp, ieflag);

    ieflag = 0;
    ip = load(0);
}
```



```
void  
cpu_interrupt()  
{  
    interrupt_pending = 1;  
}
```



```
uint8_t load(uint32_t addr) {
    if (ROMSTART <= addr
        && addr < ROMSTART + ROMSIZE) {
        return rom_load(addr - ROMSTART);
    } else if (RAMSTART <= addr
        && addr < RAMSTART + RAMSIZE) {
        return ram_load(addr - RAMSTART);
    } else {
        return 0;
    }
}

void store(uint32_t addr, uint8_t val) {
    if (RAMSTART <= addr
        && addr < RAMSTART + RAMSIZE) {
        ram_store(addr - RAMSTART, val);
    } else {
        /* Do nothing... */
    }
}
```



```
uint8_t in(uint16_t port) {
    if (SERSTART <= port
        && port < SERSTART + SERSIZE) {
        return ser_in(port - SERSTART);
    } else if (DISKSTART <= port
        && port < DISKSTART + DISKSIZE) {
        return disk_in(port - DISKSTART);
    } else ...
}

void out(uint16_t port, uint8_t val) {
    if (SERSTART <= port
        && port < SERSTART + SERSIZE) {
        ser_out(port - SERSTART, val);
    } else if (DISKSTART <= port
        && port < DISKSTART + DISKSIZE) {
        disk_out(port - DISKSTART, val);
    } else ...
}
```



```
void  
interrupt ()  
{  
    cpu_interrupt ();  
}
```



```
static const uint8_t rom[ROMSIZE] = { ... };

uint8_t
rom_load(uint32_t addr)
{
    addr %= ROMSIZE;
    return rom[addr];
}
```



# Emulation – RAM

```
static uint8_t mem[RAMSIZE];

uint8_t
ram_load(uint32_t addr)
{
    addr %= RAMSIZE;
    return mem[addr];
}

void
ram_store(uint32_t addr, uint8_t val)
{
    addr %= RAMSIZE;
    mem[addr] = val;
}
```



```
void
ser_out(uint16_t port, uint8_t val)
{
    host_print_char(val);
}
```



```
static uint8_t key, avail;

uint8_t ser_in(uint16_t port) {
    switch (port) {
        case 0:
            avail = 0;
            return key;
        case 1:
            return avail;
    }
}

void ser_step() {
    if (host_key_avail()) {
        key = host_get_key();
        avail = 1;
        interrupt();
    }
}
```



# Emulation – Disk

```
static uint8_t disk[SIZE], buf, pos, status;

void disk_out(uint16_t port, uint8_t val) {
    switch (port) {
        case 0: buf = val; break;
        case 1: pos = val; break;
        case 2:
            if (pos < SIZE) {
                if (val) disk[pos] = buf;
                else buf = disk[pos];
                status = OK;
            } else {
                status = BAD;
            }
            break;
    }
}
```



```
uint8_t
disk_in(uint16_t port)
{
    switch (port) {
        case 0: val = buf; break;
        case 1: val = pos; break;
        case 2: val = status; break;
    }
    return val;
}
```



Emulation der MMU muss *sehr* effizient sein:

- jeder Code-Zugriff braucht MMU
- jeder Daten-Zugriff braucht MMU
  - ca. 20% der Befehle lesen/schreiben Speicher
  - Grafikaufbau i.A. über `mov`-Befehle



Aufgabe der MMU:

- Suchen der virtuellen Adresse im Translation-Lookaside-Buffer (TLB)
- nicht gefunden:
  - Umrechnung der virtuellen Adresse in eine physikalische durch Lookup in Tabellen im Hauptspeicher
  - Eintragen der virtuellen und der dazugehörigen physikalischen Adresse im TLB
- Weitergabe der zur virtuellen Adresse gehörenden physikalischen Adresse an den Hauptspeicher



```
uint8_t virt_load(uint32_t vaddr) {
    uint32_t paddr;

again:
    found = tlb_lookup(vaddr & ~0xfff, &paddr);
    if (! found) {
        tlb_fill(vaddr & ~0xfff);
        goto again;
    }

    return phys_load(paddr | (vaddr & 0xfff));
}
```

tlb\_lookup sollte blitzschnell ausführbar sein und nahezu immer TRUE zurückliefern!



```
struct {
    uint32_t vaddr, paddr;
} tlb[SIZE];

int tlb_lookup(uint32_t vaddr, uint32_t *paddrp) {
    unsigned int hash = (vaddr >> 12) % SIZE;

    if (vaddr == tlb[hash].vaddr) {
        *paddrp = tlb[hash].paddr;
        return 1;
    } else {
        return 0;
    }
}
```

Entspricht einem Direct-Mapped Cache.

